

INTERNAL APPROVAL

Operational Director	
Mould Manager	
Finished Products Manager	

CUSTOMER APPROVAL

Cust Name	
Cust Signature	
Approval Date	

Customer Capacity	750mL
Fill Point Volume	753mL +5.5mL / -3mL @ 30mm
Brimful Volume	762mL Nom
Weight	600g
Max. Gas Volumes	TBA
Tilt Angle	20.7°
Process	BB

Customer Specifications - Orora Glass



Number	AG235_R31	B		
Description	750mL Premium Burgundy BVS	A		
Date & Revision	20/07/2022 Initial	Initial	Initial	20/07/2022
Finish	R31	Rev	Description	Date

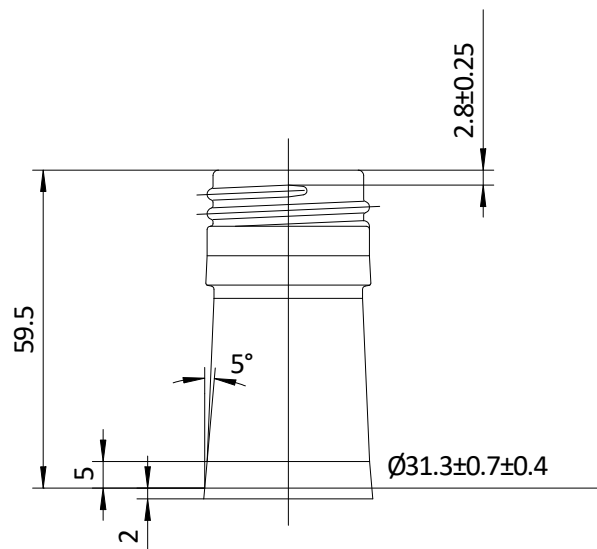
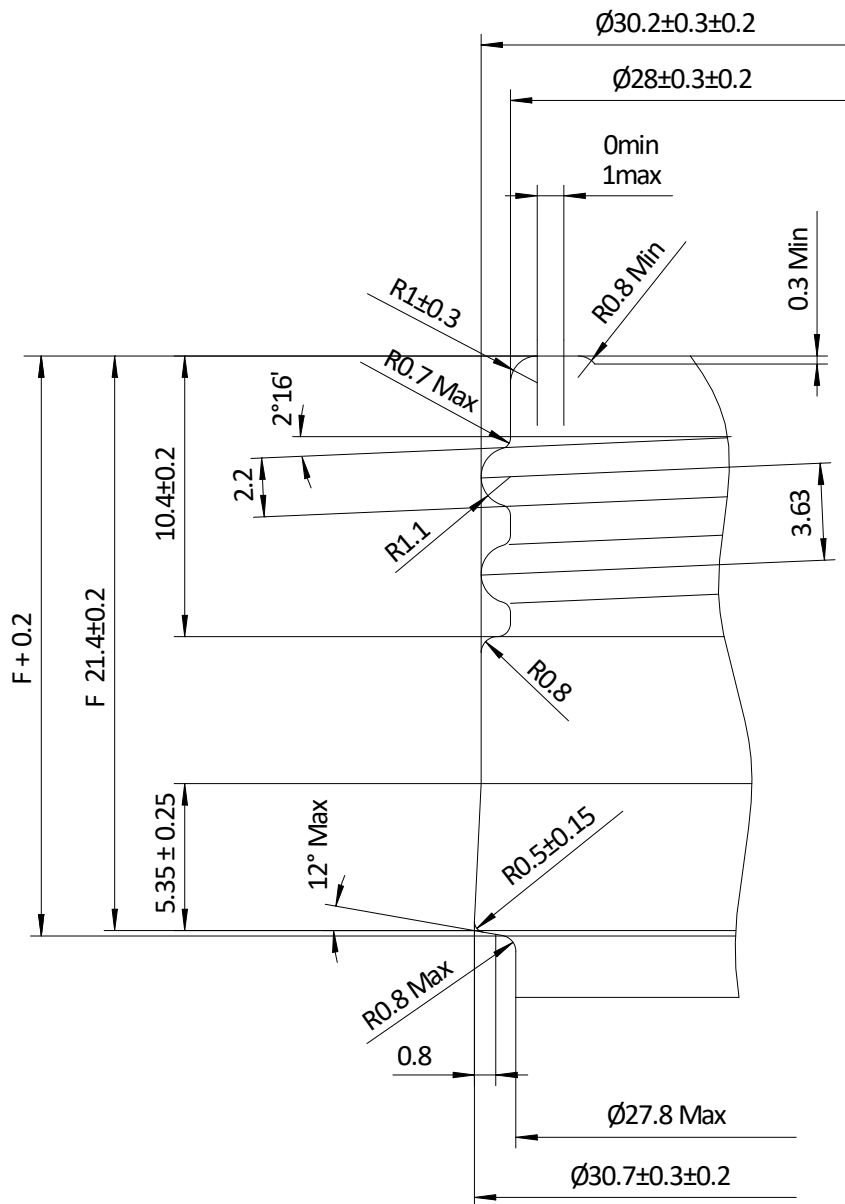

Minimum through bore diameter is 17.50mm

For diameters, the first tolerance specifies the absolute maximum and minimum tolerance, the second tolerance specifies the average.

Customer Specifications - Orora Glass



Finish Number R31

Description BVS 31.5x60 Finish

Date & Revision 22/06/2016 Initial